

SHARP®

SPC268 Sunrise Alarm Clock with USB Port Instruction Manual & Warranty

Thank you for your purchase of this quality clock. The utmost care has gone into the design and manufacture of your clock. Please read these instructions and store them in a safe place for future reference.

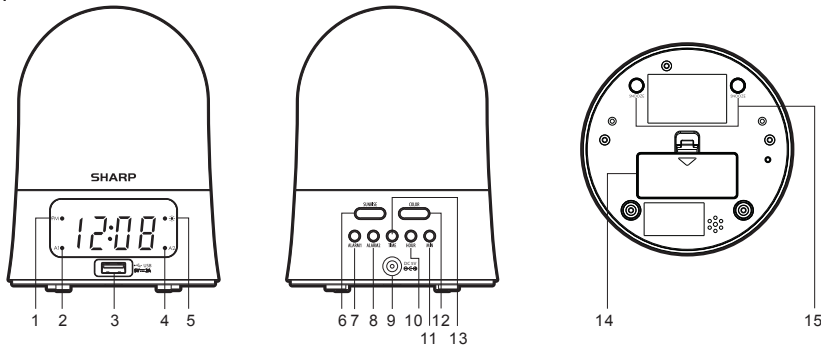

1. PM indicator
2. Alarm 1 indicator
3. USB charging port
4. Alarm 2 indicator
5. Sunrise indicator
6. **SUNRISE** button
7. **ALARM 1** button
8. **ALARM 2** button
9. **DC 5V** jack
10. **HOUR** button
11. **MIN** button
12. **COLOR** button
13. **TIME** button
14. Battery compartment
15. **SNOOZE** button

CONNECTING TO THE POWER SUPPLY

Begin by plugging in the AC adapter into a standard household outlet and the other end of the cord into the **DC 5V** jack at the back of the unit.

INSTALLING THE CLOCK & ALARM BACKUP BATTERIES

The clock time and alarm (if set) can be maintained during a power failure by 2 x AAA/ LR03 batteries (not supplied). Once the power is restored, check the time to make sure it is accurate and re-set if necessary.

Note: When battery backup is in use the display will NOT be lit. However, the clock will continue to function and the alarm will go off at its set time.

INSERTING THE BATTERIES

1. Open the battery compartment at the back of the unit by pressing on the catch and removing the cover.
2. Insert 2 x AAA/ LR03 batteries (preferably alkaline batteries) into the battery compartment, following the polarity as shown on the diagram inside the compartment.
3. Replace the battery compartment cover.

USB CHARGING

To charge, connect your USB device to the USB port of this clock.

Note:

- Use only with devices that require 5V USB power.
- The USB port provides 2,000mA recharging current. Devices requiring more than 2,000mA should not be used.
- Charging time may vary for different devices.

SETTING THE CLOCK

- Press and hold the **TIME** button down to activate time setting.
- While holding down the **TIME** button, press the **HOUR** button to advance to the correct hour. The PM indicator will light when the hour is advanced into the PM time.
- While holding down the **TIME** button, press the **MIN** button to advance to the correct minute.
- Release the **TIME** button when the correct time is shown on the display.

SETTING THE ALARM

- Press and hold the **ALARM 1 / 2** button down to activate alarm setting.
- While holding down the **ALARM 1 / 2** button, press the **HOUR** button to advance to the correct hour. The PM indicator will light when the hour is advanced into the PM time.
- While holding down the **ALARM 1 / 2** button, press the **MIN** button to advance to the correct minute.
- Release the **ALARM 1 / 2** button when the correct alarm time is shown on the display.

USING THE ALARM FUNCTION

- Press the **ALARM 1 / 2** button to activate the alarm and the alarm indicator will be lit.
- Press the **ALARM 1 / 2** button again to deactivate the alarm and the alarm indicator no longer be visible.

SNOOZE FUNCTION

- Pressing the **SNOOZE** button after the alarm sounds will cause the alarm to stop and the alarm will sound again in 9 minutes. This will happen each time the **SNOOZE** button is pressed.

COLOR CHANGING LIGHT FUNCTION

- Press the **COLOR** button to activate the color changing light.
- Press the **COLOR** button again if you want to freeze the color.
- Press and hold the **COLOR** button to deactivate the color changing light.

SUNRISE LIGHT FUNCTION

This alarm clock has sunrise light function where the light will gradually light up 30 minutes before the alarm sounds.

- Press the **SUNRISE** button to activate this function once the **ALARM 1** is set.
- To cancel it, press the **SUNRISE** button.

Note: ALARM 1 is enabled with the SUNRISE function; alarm 2 is NOT.

CARE OF YOUR CLOCK

- Replace the back up battery annually, or store the clock without a battery when not in use.
- A soft cloth or a paper towel may be used to clean your clock.
- Do not use any corrosive cleanser or chemical solutions on the clock.
- Keep your clock dry; if it gets wet, wipe it dry immediately. Keep your clock away from dust and dirt. Handle your clock carefully; do not drop it.
- Do not subject the clock to excessive force, shock, dust, temperature, or humidity. Any of these conditions may shorten the life of the clock.
- Do not tamper with any of the internal components of this clock. This will invalidate the warranty and may cause damage.

**For Customer Service Please Call Toll Free at
1-(800)-221-0131 and ask for Customer Service.
Monday-Friday 9:00 AM - 4:00 PM EST**

One Year Limited Warranty

M.Z. Berger & Company warrants the original consumer purchaser of this product that it shall be free of defects in materials and workmanship for one year from the purchase date of this product. Defects caused by tampering, improper use, unauthorized modifications or repairs, immersion in water or abuse are not covered by this warranty. If a defect covered by this warranty occurs during the warranty period, wrap your clock carefully and send it to the following address:

MZ Berger Service Center
29-76 Northern Boulevard
Long Island City, NY 11101

You must include a Proof of Purchase, either the original receipt or a photocopy and a check or money order for USD \$6.00 to cover the cost of handling. Also include your return address inside the package. M.Z. Berger will repair or replace the clock and return it to you. M.Z. Berger will not be liable for any loss or damage, including incidental or consequential damages of any kind; from any breach of warranty either expressed or implied relating to the product. Since some states do not allow the exclusion or limitation of incidental or consequential damages, this limitation may not apply to you.

Printed in China

Model SPC268

SHARP registered in the U.S. Patent and Trademark office.

IMPORTANT SAFETY INSTRUCTIONS

1. Read these Instructions.
2. Keep these Instructions.
3. Heed all Warnings.
4. Follow all instructions.
5. Do not use this apparatus near water.
6. Clean only with a dry cloth.
7. Do not block any ventilation openings. Install in accordance with the manufacturer's instructions.
8. Do not install near any heat sources such as radiators, heat registers, stoves, or other apparatus (including amplifiers) that produce heat.
9. Do not defeat the safety purpose of the polarized or grounding - type plug. A polarized plug has two blades with one wider than the other. A grounding type plug has two blades and a third grounding prong. The wide blade or the third prong are provided for your safety. When the provided plug does not fit into your outlet, consult an electrician for replacement of the obsolete outlet.
10. Protect the power cord from being walked on or pinched particularly at plugs, convenience receptacles, and the point where they exit from the apparatus.
11. Only use attachments/accessories specified by the manufacturer.
12. Use only with a cart, stand, tripod, bracket, or table specified by the manufacturer, or sold with the apparatus. When a cart is used, use caution when moving the cart/apparatus combination to avoid injury from tip-over.
13. Unplug this apparatus during lightning storms or when unused for long periods of time.
14. Refer all servicing to qualified service personnel. Servicing is required when the apparatus has been damaged in any way, such as power-supply cord or plug is damaged, liquid has been spilled or objects have fallen into the apparatus, the apparatus has been exposed to rain or moisture, does not operate normally, or has been dropped.



FCC WARNINGS

WARNING: Changes or modifications to this unit not expressly approved by the party responsible for compliance could void the user's authority to operate the equipment.

NOTE: This equipment has been tested and found to comply with the limits for a Class B digital device, pursuant to Part 15 of the FCC Rules. These limits are designed to provide reasonable protection against harmful interference in a residential installation. This equipment generates, uses, and can radiate radio frequency energy and, if not installed and used in accordance with the instructions, may cause harmful interference to radio communications. However, there is no guarantee that interference will not occur in a particular installation. If this equipment does cause harmful interference to radio or television reception, which can be determined by turning the equipment off and on, the user is encouraged to try to correct the interference by one or more of the following measures:

- Reorient or relocate the receiving antenna.
- Increase the separation between the equipment and receiver.
- Connect the equipment into an outlet on a circuit different from that to which the receiver is connected.
- Consult the dealer or an experienced radio/TV technician for help.



WARNING: TO REDUCE THE RISK OF ELECTRIC SHOCK, DO NOT REMOVE COVER (OR BACK). NO USER-SERVICEABLE PARTS INSIDE. REFER SERVICING TO QUALIFIED SERVICE PERSONNEL.

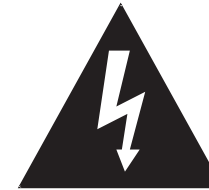

The lightning flash with arrowhead symbol, within an equilateral triangle, is intended to alert the user to the presence of uninsulated “dangerous voltage” within the product’s enclosure that may be of sufficient magnitude to constitute a risk of electric shock to persons.



The exclamation point within an equilateral triangle is intended to alert the user to the presence of important operating and maintenance (servicing) instructions in the literature accompanying the appliance.

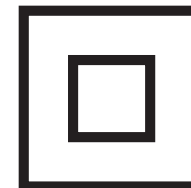

This symbol indicates that this product incorporates double insulation between hazardous mains voltage and user accessible parts.